

Rotary Vane Vacuum Pumps

TMSRV400

Dimensional Drawing

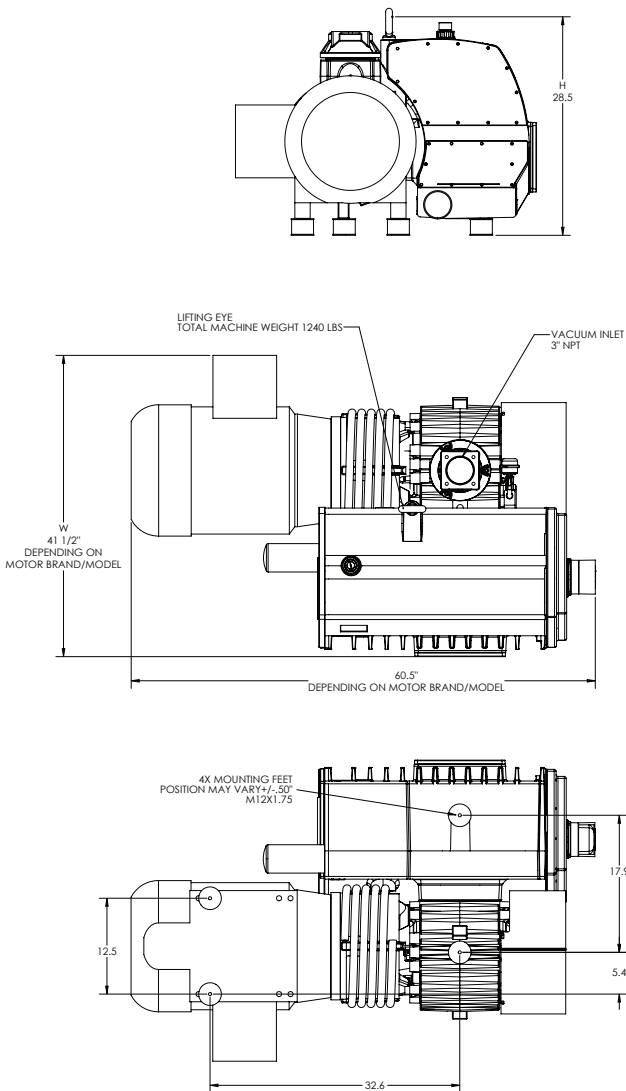

Pumping Speed

Air at 70 °F. Tolerance: ± 10%

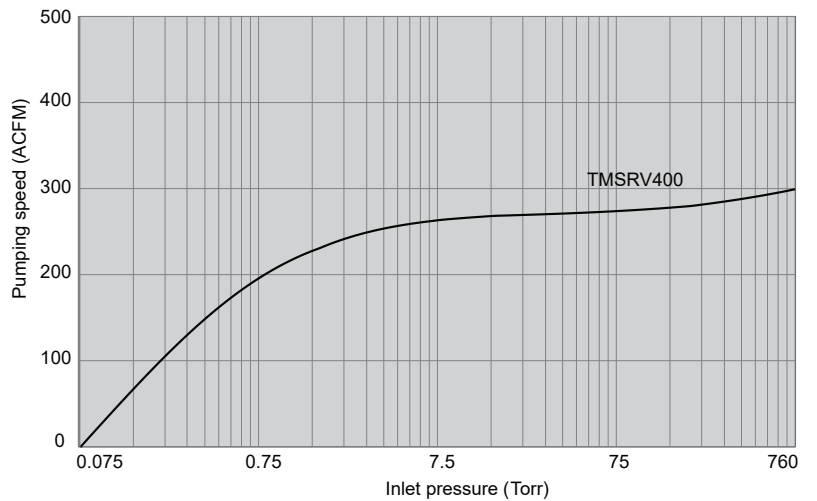

| Technical Data | UOM | TMSRV400 |
|--|--------|--------------------|
| Max. pumping speed | ACFM | 305 |
| Ultimate pressure | Torr | 0.075 |
| Nominal motor rating | HP | 15 |
| Power consumption at 75 Torr | HP | 13.4 |
| Power consumption at ultimate pressure | HP | 7.5 |
| Nominal motor speed | RPM | 1150 |
| Sound level (ISO 2151) | dB(A) | 79 |
| Oil capacity | Qts. | 14 |
| Approximate weight | Lbs. | 1084 |
| Dimensions (L x W x H) | inches | 60 ½ x 41 ½ x 28 ½ |
| Gas inlet | NPT | 3" |

All performance data is based on ambient conditions of 14.7 PSIA and 70 °F, and has a tolerance of ± 10%.



Learn more by scanning here or contacting us at info@tmsvacuum.com
 Trust the **TMS Difference.** | tmsvacuum.com